

PRENTICE

2124 Knuckleboom Loaders



Built Better Than It Needs To Be

The new Prentice 2124 has a light-weight, yet strong A-frame design based on a clean, simple pedestal fabricated from high strength steel. The smooth reliable hydraulic system, superior lift capacity and excellent controllability make it the ideal self-loader for the pulpwood and short log markets.



PLATFORM

Operator's platform features large adjustable operator's seat with padded armrests. Joystick control valves designed to provide smooth and consistent loader control. Access ladders and hand grabs are positioned for maintaining "three point" contact. Swing system provides quick, smooth and controlled response to joystick commands.

HYDRAULIC

The 3200 PSI hydraulic system maximizes lift capacity and improves controllability of the loader during multi-function operations. Redesigned continuous rotation assembly improves hose routings and ease of maintenance. A 5-circuit hydraulic swivel is standard.

ELECTRICAL

An 8-circuit electrical collector standard for providing electrical power and setting stabilizers. Work light packages for stick boom and operator's platform are optional. Optional 25' (7.62 m) Teleboom features thumb-switch proportional control.



STRUCTURAL

A-Frame pedestal is formed of high strength steel to maximize strength and minimize weight.

BOOM STRUCTURE

Castings at main boom base, midpoint and stick end minimize weight and maximize strength.

Photos may not represent standard machine configuration.

PRENTICE 2124 SELF-LOADER TRUCK MOUNT

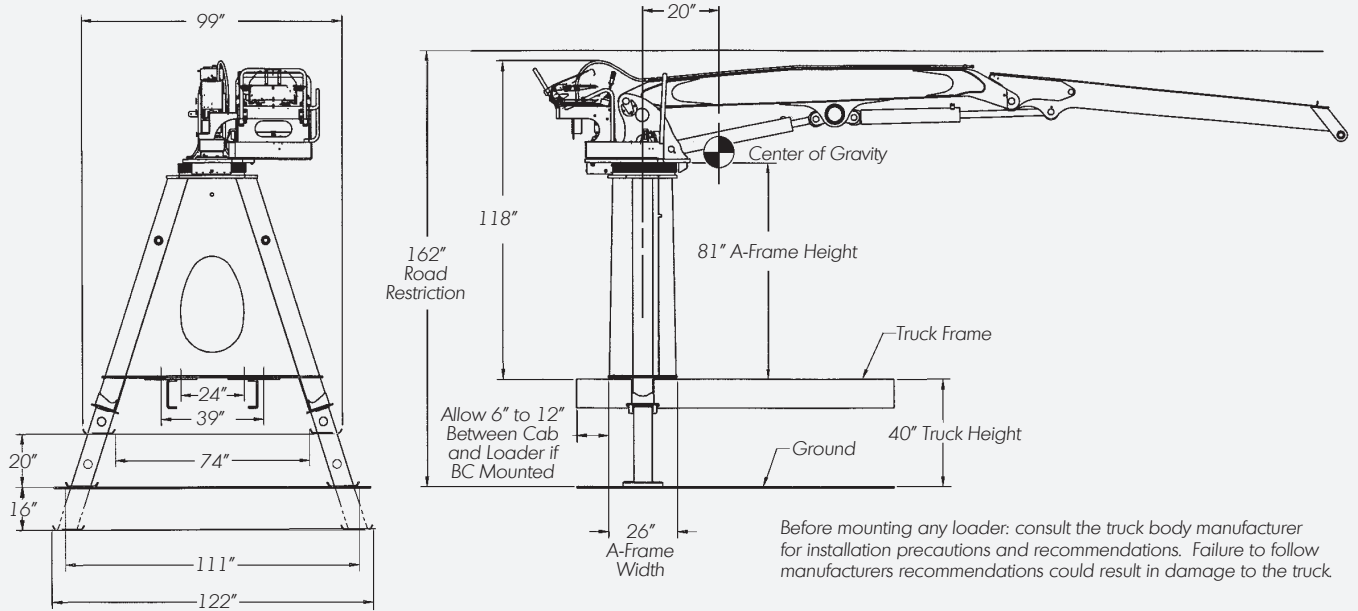

Minimum Carrier is a single axle truck with frame section modules of 18 cu. in. and GVW rating of 27,000 lbs.

Recommended Carrier is a live tandem truck with frame section modules of 18 cu. in. and GVW rating of 32,000 lbs.

PRENTICE 2124 SELF-LOADER TRAILER MOUNT

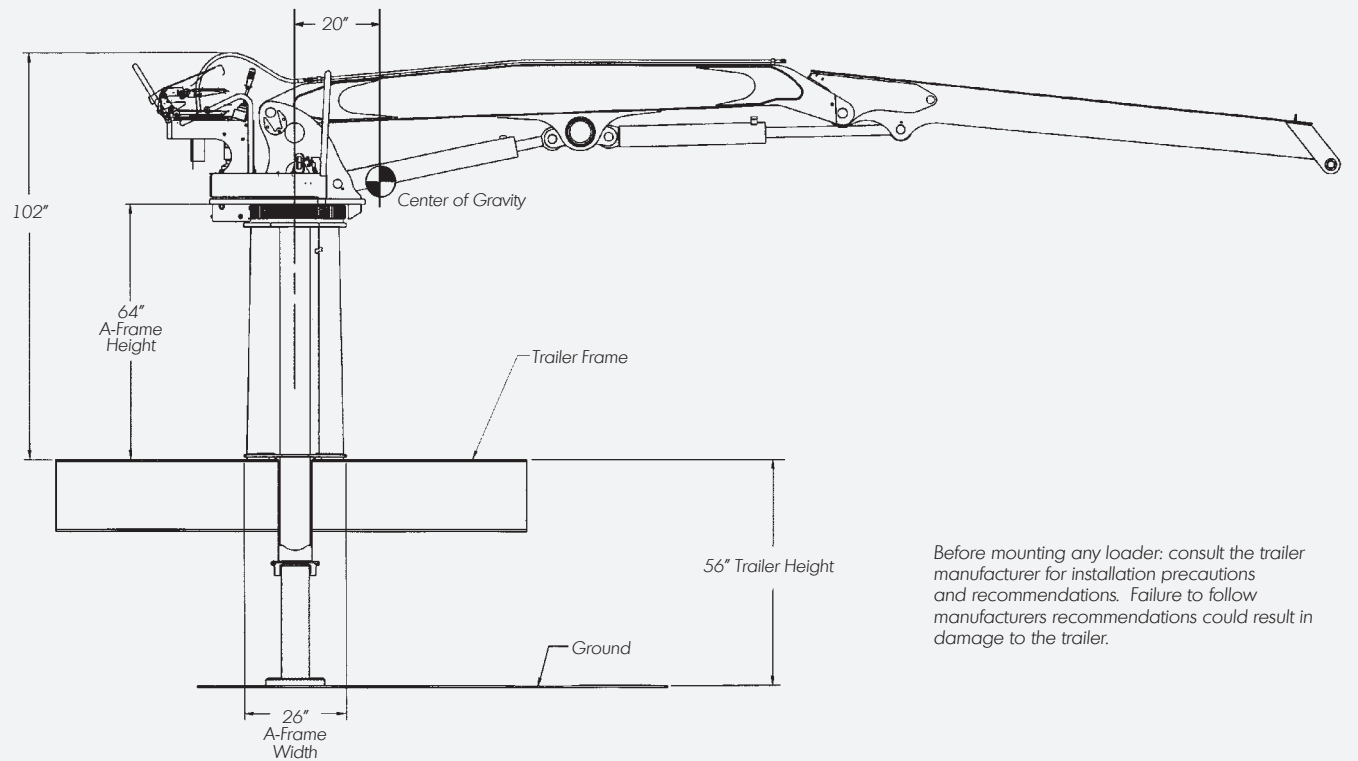

2124 LIFT CAPACITY

Lift Capacity Chart PRENTICE 2124 · Boom Type: Knuckleboom · Boom length: 22' (6.7m)

	1.5m (5'/)		3m (10'/)		4.6m (15'/)		6.1m (20'/)		Full Reach
	kg.	lbs.	kg.	lbs.	kg.	lbs.	kg.	lbs.	
9.1m (30'/)			2507	5528					2962
7.6m (25'/)					2092	4613			2500
6.1m (20'/)					2358	5198	1508	3324	2298
					2430	5358			
4.6m (15'/)			3103	6842	2735	6030	1846	4070	2314
			3459	7626	2610	5755	2062	4545	
3m (10'/)	1802	3974	4230	9325	2886	6363	2082	4591	2242
			4037	8900	2747	6056	2058	4538	
1.5m (5'/)	2222	4898	4109	9058	2710	5974	1625	3582	2327
			3904	8608	2569	5664	1972	4349	
0 0.0			2968	6544	1854	4087			3329
			2800	6172	1741	3838	1528	3369	

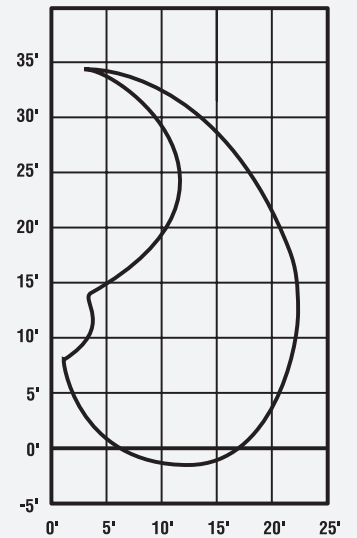

Lift Capacity Chart PRENTICE 2124 · Boom Type: Knuckleboom · Boom length: 25' (7.62m)

	1.5m (5'/)		3m (10'/)		4.6m (15'/)		6.1m (20'/)		Full Reach
	kg.	lbs.	kg.	lbs.	kg.	lbs.	kg.	lbs.	
9.1m (30'/)					1803	3975			1995
7.6m (25'/)					2072	4569			1693
					1776	3915	1478	3259	
6.1m (20'/)					2041	4500	1699	3745	1634
					1859	4099	1661	3663	
4.6m (15'/)					2107	4645	1910	4211	1769
					2178	4802	1891	4169	
3m (10'/)	5789	12762	3611	7960	2748	6059	2134	4706	1693
	6680	14727	3662	8074	2614	5764	2021	4456	
1.5m (5'/)	2303	5077	4233	9332	2831	6243	2068	4460	1642
	2647	5835	4021	8864	2683	5915	1908	4207	
0 0.0	2958	6522	3715	8191	2445	5390	1459	3216	2592
	3400	7496	3509	7736	2303	5077	1361	3001	

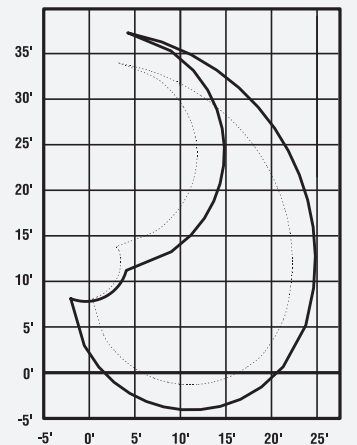

NOTES:

Capacities shown in "Black" are 100% of main cylinder hydraulic capability; capacities shown in "Red" are 87% of hydraulic capacity.

Notice that some of the lifts in "Red" are higher than main only, since the stick has mechanical advantage and the limiting lift is the main relief.

2124 SPECIFICATIONS

HYDRAULIC SYSTEM

Type	Split flow tandem circuit hydraulic system. System pressure 3200 psi. (2,249,822.7 kg)
Operation	Fully independent simultaneous operation of main boom and swing. Flow diverted to operate stabilizers.
Control Valves	Stack sections with mechanical joysticks. Valves contain port reliefs and anti-cavitation valves for loader protection and control. Port relief settings are 2,671,664.4 kg (3800 psi.)
Cylinders	114.3 cm (4.5") Main and stick double acting with solid rods.
Diagnostic Nipples	Located at control valves.
Oil Filter	Two return spin on filters, 2 nominal/10 absolute micron filter. Twenty five micron case drain filter.
Oil Reservoir	159 liters (Forty two [42] gallon) capacity. Filtered breather, sight gauge. Cylindrical design, aluminum fabrication.
Pump Mounting	Direct mounted PTO driven, bi-rotational, delivering 151 liters (40 GPM). (Optional Chassis mount configuration.)
Loader Pump	Tandem gear type (21 + 19) operating at 1650 rpm (max) through PTO. Pump rated for 2,460,743.5 kg (3500 psi.)
Swivel	Steel barrel with Durabar core. Five passages for pressure, return and stabilizers. Eight ring electric collector standard for optional light packages.
Hoses & Hydraulic Tubes	2,812,278.3 kg (4000 psi) rated hose with wear resistant coating. Steel ORS tubing.
Fittings	ORS fittings.

KNUCKLE BOOM

Boom Length	6.7 m (22') horizontal reach. 10.3 m (34') working height to boom tip. (Optional Tele-Boom): 10.3 m (25') horizontal reach. 11.2 m (37') working height to boom tip.
Boom Structure	Boom is high tensile steel fabrication. Main boom equivalent to 25.4 cm (10") x 15.2 cm (6") Spar tube. Stick boom equivalent to 20.3 cm (8") x 15.2 cm (6") spar tube.
Construction	Welded high tensile steel "Knuckle type" boom with heat treated high alloy steel pins and aluminum-bronze pivot bushings; self-aligning bushings at both ends of main and stick boom cylinders. Boom & cylinder pin bushings are greased through pins. Castings at base end, stick end and midpoint of mainboom assembly

STABILIZERS

Type	Telescopic A-frame stabilizers with individual platform controls for uneven terrain.
Structural	Stabilizer legs are 17.8 cm (7") x 17.8 cm (7") high tensile steel tubing.
Stab Pads	Stabilizer pads measure 25.4 cm (10") x 38.1 cm (15").
Clearances	Ground clearance for stabilizers in retracted position is 50.8 cm (20"). Below grade reach in extended position is 40.6 cm (16").
Stowed	Stabilizers stowed position 251.4 cm (99") wide. Width at grade level 284.4 cm (112") on 101.6 cm (40") truck. Width fully extended 284.4 cm (122").

STRUCTURAL

Pedestal	"A-Frame" pedestal design is formed high strength steel plate.
Swing System	Continuous rotation; ring and pinion gear set driven by an axial piston hydraulic motor through a planetary gearbox. Slewing ring is 65.1 cm (25.65") diameter. Swing torque 71,014.91 kg (14,545 ft.lbs.).
Travel	Swing system is secured by house lock during transit.
Travel Height	33.5 cm (13' 2") maximum stowed height above ground 101.6 cm (40") truck frame height
Weight	2,585.4 kg (5,700 lbs) for the 6.7 m (22') fixed boom model and 2744.23 kg (6,050 lbs) for the 7.62 m (25') tele boom model.
Mounting	"A-frame" mounting base is 90.8 cm (35 3/4") wide x 66 cm (26") long for mounting on standard truck chassis.

CYLINDERS

Main Boom	(1) 11.4 cm (4.5") Bore x 6.3 cm (2 1/2") Rod
Stick Boom	(1) 11.4 cm (4.5") Bore x 6.3 cm (2 1/2") Rod
Stabilizers	(2) 7.6 cm (3") Bore x 5 cm (2") Rod

OPERATION OF LOADER

Operator's Platform	Platform right side mounted with fold over seat. Access to platform by single ladder.
Seat	Fold down seat with armrests
Controls	Two mechanical joysticks and proportional teleboom controls. Swing pedal with mechanical linkage. Individual controls for activation of stabilizer.

WEIGHT

5700 lbs. with 22' boom
Add 250 lbs for 25' teleboom option

CAPACITY (Note: SAE Standard 87% Ratings)

Radius	Elevation	Lift Capacity	
1.5 m (5')	1.5 m (5')	2,290.6 kg	(5,050 lbs.)
3 m (10')	1.5 m (5')	3,865.9 kg	(8,523 lbs.)
4.5 m (15')	1.5 m (5')	2,525.1 kg	(5,567 lbs.)
6 m (20')	1.5 m (5')	1,481.4 kg	(3,266 lbs.)
6.7 m (22')	1.5 m (5')	945.2 kg	(2,084 lbs.)

Note: Deduct grapple weight for payload



www.prenticeforestry.com

Caterpillar Forest Products
100 S.L. White Blvd.
LaGrange, GA 30241

We reserve the right to change specifications and to improve our products without notice or obligation. Photos may not represent standard machine configuration.

Form No. PRSL-0408 · Printed in U.S.A.